

FOUR YEAR B.TECH. (SSAC) DEGREE EXAMINATION, JANUARY 2013

Third Year Examination

First Semester

Computer Science and Engineering

THEORY OF COMPUTATION

(Revised Regulations w.e.f. academic year 2010–2011)

[Common to CSE/IT Branches]

Time : Three Hours

Maximum : 60 Marks

*Answer any five questions, choosing one question from each unit.
All questions carry equal marks.*

Unit I

1. (a) Prove that, if L is accepted by an NFA with ϵ -transitions, then L is accepted by an NFA without ϵ -transitions.

(6 marks)

- (b) Design a Moore Machine to determine the residue mod 4 for each binary string treated as integer.

(6 marks)

Or

2. (a) What are the applications for finite automata ?

(6 marks)

- (b) Explain the conversion of DFA into regular expression using the Arden's theorem.

(6 marks)

Unit II

3. (a) State and prove Myhill Nerode's theorem.

(6 marks)

- (b) Define Regular expression and prove that for every regular expression there exist an NFA with ϵ -transitions.

(6 marks)

Or

4. (a) Explain about the conversion of NFA to DFA with an example.

(8 marks)

- (b) Consider G whose productions are $S \rightarrow aAS \mid a$, $A \rightarrow SbA \mid SS \mid ba$. For the string $w = aabbaa$ find the leftmost and rightmost derivation.

(4 marks)

Turn over

Unit III

5. (a) Explain the terms : Push down Automata and context free language. (6 marks)
 (b) Let G be a CFG with the following productions :

$$S \rightarrow a B c$$

$$A \rightarrow a b c$$

$$B \rightarrow a A b$$

$$C \rightarrow A B$$

$$C \rightarrow ! c$$



Construct a PDA M such that the language generated by M and G are equivalent.

(6 marks)

Or

6. (a) What do you mean by ambiguity ? Show that the grammar $S \rightarrow S/S, S \rightarrow a$ is ambiguous. (6 marks)
 (b) Explain about the Griebach normal form with an example. (6 marks)

Unit IV

7. (a) State and prove the Pumping lemma for CFL with its applications. (6 marks)
 (b) Write in detail about the Decision algorithm for CFL. (6 marks)

Or

8. Give a Turing machine for the following :
 (a) That computes ones complement of a binary number. (6 marks)
 (b) That shifts the input string, over the alphabet (0, 1) by one position right by inserting # as the first character. (6 marks)

Unit V

9. (a) Prove that the function $fadd(x, y) = x + y$ is primitive recursive. (6 marks)
 (b) Prove that there exists a recursively enumerate language whose complement is not recursively enumerable. (6 marks)

Or

10. (a) Prove that the union and intersection of two recursive languages are also recursive. (6 marks)
 (b) Prove that halting problem is undecidable. (6 marks)

B.Tech. DEGREE EXAMINATION, NOVEMBER 2012

THIRD YEAR EXAMINATION

FIRST SEMESTER

Branch: CE

Paper — SOIL MECHANICS

Time : 3 Hours

Max. Marks : 60

Answer ONE question from each Unit.

UNIT - I

1. (a) Establish the relation among Void Ratio, Degree of saturation, water content and specific gravity of soil solids. (6)
- (b) A partially saturated soil from an earth fill has a natural water content of 19% and a bulk unit weight of 19 kN/m^3 . Assuming the specific gravity of soil solids as 2.7, compute the degree of saturation and void ratio. if subsequently the soil gets saturated, determine the dry density, buoyant unit weight and saturated unit weight. (6)

Or

2. (a) Differentiate among 'well graded', 'poorly graded', and 'gap graded' soils with neat sketches (6)
- (b) Classify the soil with following properties as per Indian Standard Soil Classification system.
 - (i) soil passing 4.75mm sieve = 85%
 - (ii) soil passing 0.075mm sieve = 62%
 - (iii) Liquid Limit = 42%
 - (iv) Plastic Limit = 23%
 - (v) $C_u = 5$
 - (vi) $C_c = 2.2$(6)

UNIT - II

3. (a) Distinguish between 'Discharge Velocity' and 'Seepage Velocity'. Derive relation between them. (6)
- (b) Describe various factors that affect Compaction of soils. (6)

Or

4. (a) What is 'Quick Sand' Condition? When does it occur? How Quick sand condition can be avoided in Sands? (6)
- (b) Calculate the coefficient of permeability of a soil sample 8cm in height and cross sectional area 60 cm^2 . It is observed that in 15 minutes, 600ml of water passed down under a constant 65cm. on oven drying, the test specimen weighs 750g. Calculate seepage velocity of water during the test if $G = 2.70$. (6)

UNIT - III

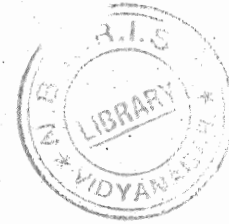

5. (a) Distinguish between
- (i) 'Coefficient of compressibility' and 'compression index'
 - (ii) Normally consolidated and Preconsolidated soils. (6)
- (b) Estimate the consolidation settlement of a square footing of size $2\text{m} \times 2\text{m}$ installed in a soil at a depth of 1.5m in a saturated clay deposit if it transmits a load of 250 kN . The Natural water content of foundation soil is 32% , Liquid limit is 40% and specific gravity is 2.70 . The water table is at the ground surface and soil has a unit weight of 20kN/m^3 . The Thickness of clay layer is 6m and is underlain by rock. Assume the soil as normally consolidated. (6)

Or

6. (a) Derive Terzaghi's one dimensional Consolidation equation. (9)
- (b) A saturated clay layer of 3m thickness took 12 years to complete 30% consolidation under Single drainage. How much time does the same clay layer take to complete the same percentage of consolidation if it has double drainage? (3)

UNIT - IV

7. (a) Describe Mohr-Coulomb Theory used in Evaluation of shear strength of soils. (6)
- (b) An unconfined compression test was performed on an undisturbed clay specimen. The sample had a diameter of 38mm and length of 76mm . The load at failure was 30N and the axial deformation of the sample was 10mm . Determine the undrained shear parameters of soil if the failure plane made an angle of 30° with vertical. (6)

Or

8. (a) Discuss relative merits and demerits of Direct Shear test over Triaxial Test. (6)
- (b) Unconfined compressive strength of a soil is found to be 150 kN/m^2 . A Sample of same soil failed at a deviator load of 160 kN/m^2 under a cell pressure of 100 kN/m^2 . Determine shear Parameters of the soil. (6)

UNIT - V

9. (a) What is 'Newmark Chart'? How is it constructed? What are its uses? (8)
- (b) Distinguish between 'Pressure Bulb' and 'Influence Diagram' (4)

Or

10. (a) Derive an Expression for calculation of vertical stress at a point located at a depth 'z' centrally below a uniformly loaded circular area of intensity 'q'. Use Boussinesq's Theory. (6)
- (b) A line load of 100kN/m extends to a long distance on ground surface. Determine the intensity of vertical stress at a point 1.5m below the surface
- (i) directly under the line load and
 - (ii) at a distance 1m perpendicular to the line load. Use Boussinesq's Theory. (6)

(10 CE 19)

(10 CE 18)

FOUR YEAR B.Tech. DEGREE EXAMINATION, NOVEMBER 2012

THIRD YEAR EXAMINATION

FIRST SEMESTER

Branch – Civil Engineering

Paper — STEEL STRUCTURAL DESIGN

Time : 3 Hours

Max. Marks : 60

Use of IS 800-1984 and Structural Steel Tables are permitted.

Answer FIVE questions, choosing ONE full question from each Unit.

Assume any data, if found necessary suitably.

UNIT – I

1. (a) Discuss the failures of riveted connections with neat sketches. (4)
- (b) Find the maximum force which can be transmitted through the double covered butt joint to connect two plates of thickness 10 mm. If $\sigma_{at} = 150 \text{ N/mm}^2$, $\sigma_{pf} = 250 \text{ N/mm}^2$ and $\tau_{vf} = 80 \text{ N/mm}^2$, find the efficiency of the joint using 20 mm diameter rivets. (8)

Or

2. Design a bracket I Section welded to a steel stanchion by using flange weld and web welds. The size of flange weld is 1.5 times that of web weld. Determine the suitable size of the weld taking the permissible stress in weld as 110 MPa. (12)

UNIT – II

3. (a) What is a plug and slot weld? Design a butt welded joint to connect two plates of $500 \text{ mm} \times 10 \text{ mm}$ and $500 \text{ mm} \times 12 \text{ mm}$ for the full strength. (6)
- (b) A column section I.S.H.B @ 150, 0.27 kN/m is to be spliced with another column section I.S.H.B 150 @ 0.35 kN/m. The load on the column is 300 kN. Design the column splice. Assume $f_y = 250 \text{ N/mm}^2$. (6)

Or

4. Design a column with two channels placed toe to toe battened to support a load of 800 kN. The effective length of the column is 4.5 m. Also design battens. (12)

[P.T.O]

UNIT - III

5. Design a simply supported beam to carry a udl of 26 kN/m in addition to its own weight over a span of 5.5 m. The overall depth of beam should not exceed by 350 mm. Use plates on the compression side only if necessary. (12)

Or

6. A beam consisting of ISMB 600 @ 122.6 kN/m is simply supported over a span of 8 m. Determine the safe load that the beam can carry assuming that the beam is laterally supported. Take $f_y = 250 \text{ N/mm}^2$ and $E = 2.10 \times 10^5 \text{ N/mm}^2$. (12)

UNIT - IV

7. Design a gantry girder to carry an electric overhead traveling crane to suit the following data.

Crane Capacity : 190 kN

Weight of Crab : 80 kN

Weight of Crane : 160 kN

Minimum approach of crane hook : 1.1 m

Distance between centers of crane wheels : 3.2 m

Distance between cranes of gantry girders : 15.0 m

Span of gantry girder : 6 m

Weight of rail section : 0.3 kN/m

Height of rail section : 75 mm. (12)

Or

8. A simply supported beam of 8 m effective span carries a udl of 30 kN/m inclusive of self weight ISMB 150 and 12 mm thick plates only are available. Design a suitable beam if the flange of the beam is laterally restrained and $f_y = 250 \text{ MPa}$. (12)

(10 CE 18)

UNIT - V

9. A column section ISMB 360 @ 0.67 kN/m with one cover plate 400 mm × 15 mm on either side is carrying an axial load of 2200 kN. Design a suitable gusseted base. The allowable bearing pressure in concrete is 4 MPa. (12)

Or

10. A column 5.00 m effective length is made up of 21 SMC 250 @ 0.304 kN/m with spacing 150 mm back to back and connected with plates of 10 mm thick. Design a suitable gusseted base if the safe bearing capacity of soil is 400 kN/m². Use M 25 grade concrete. (12)

(10 CE 20)

FOUR YEAR B.Tech. DEGREE EXAMINATION, NOVEMBER 2012

THIRD YEAR/FIRST SEMESTER

Branch — CE

Paper — HIGHWAY ENGINEERING — II

Time : 3 Hours

Max. Marks : 60

Answer ONE question choosing from each unit.

UNIT - I

1. How are pavements classified based and their structural behaviours? Draw neat sketches showing their component layers? Also explain the function of each and every component layer. (12)

Or

2. (a) What is equivalent single wheel load? Explain its significance with a neat sketch. (6)
(b) Explain the various factors to be considered for the design of pavements. (6)

UNIT - II

3. (a) List out with equations, the critical stresses at interior, edge and corner regions of a cement concrete slab as given by western guard. (6)
(b) What are the different temperature stresses developed in co pavements? Explain them. (6)

Or

4. (a) How are the expansion and contraction joint spacing designed? Explain with equations. (6)
(b) Define the terms : Radius of relative stiffness and equivalent Radius of resisting section. (6)

UNIT - III

5. Explain the detailed procedure for the construction of water bound macadam roads with specification of materials. (12)

Or

6. Describe the construction steps for cement concrete pavement slab. (12)

UNIT - IV

7. Explain the construction procedure for Bituminous macadam with specifications of materials used. (12)

Or

8. (a) Enumerate the importance of highway drainage. (6)
(b) Explain the requirements of good highway drainage system. (6)

[P.T.O]

UNIT - V

9. (a) List out the general causes of pavement failures. (4)
(b) Explain with typical flexible pavement failures with sketches. (8)

Or

10. (a) Discuss the reasons for the failure of cement concrete pavements. (6)
(b) Explain typical rigid pavement failures with sketches. (6)

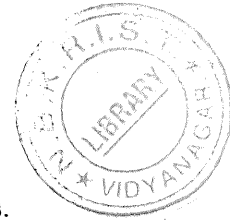

(10 CE 16)

FOUR YEAR B.Tech. DEGREE EXAMINATION, NOVEMBER 2012

THIRD YEAR/FIRST SEMESTER

Branch - CE

Paper — STRUCTURAL ANALYSIS — I

Time : 3 Hours

Max. Marks : 60

Answer One question from each unit.

UNIT - I

- Derive the relationship between the curvature, slope and deflection of the beam. (6)
 - Prove that in case of simply supported beam subjected to central point load 'W' over the span, the max. deflection is given by $\frac{WL^2}{16EI}$. Use moment area method. (6)

Or

- A beam, simply supported at ends A and B is loaded with two points loads of 60 kN and 50 kN at distance 1m and 3 m respectively from end 'A'. Determine the position and magnitude of maximum deflection. Take $E = 2 \times 10^5 \text{ N/mm}^2$ and $I = 8500 \text{ cm}^4$. (12)

UNIT - II

- Use method of joints to find the forces in the members of the truss as shown in Fig. 1. (12)

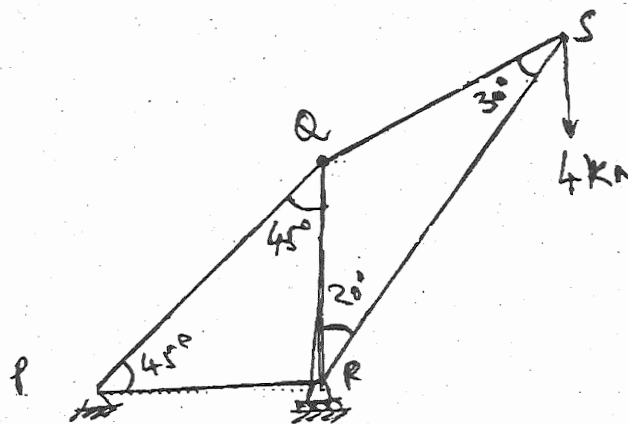

Fig. 1

Or

- Solve the problem 3 using the method of sections. (12)

[P.T.O]

UNIT - III

5. A cantilever of length 'L' is loaded with uniformly distributed load of 'w' per unit length over the whole span. It is propped at the free end. If the prop is rigid calculate the propeaction and draw SFD and B.M.D. (12)

Or

6. Analyse the beam of span 'L' has its ends fixed and carries a uniformly distributed load of w/unit length from end to the mid-span. Draw the S.M.D. and SFD. (12)

UNIT - IV

7. A beam ABC of length 2l rests on three supports equally spaced and is loaded with U.D.L. w/unit length throughout the length of the beam as shown in Fig. 2. Plot the B.M.D. and SFD. (12)

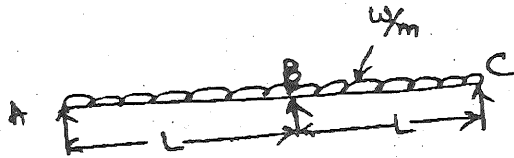

Fig 2

Or

8. A continuous beam ABC is fixed at ends A and C and freely supported at B. The span AB = 6 m and BC = 3 m. The span AB carries a udl of 10 kN/m and span BC carries a udl of 20 kN/m. The beam has constant flexural rigidity. Find the moments over the beam and draw the BMD and SFD. (12)

UNIT - V

9. (a) State and prove Castigliano's first theorem. (6)
 (b) On the basis of the strain energy principle derive an expression for the force and deflection of a cantilever beam carrying a load W at its free end. Calculate the value of the deflection and the strain energy stored in the beam if the load $W = 50 \text{ kN}$, span is 2 m, $E = 200 \text{ kN/mm}^2$ and $I = 5 \times 10^{-4} \text{ m}^4$. (6)

Or

10. Determine the horizontal displacement of joint D of the truss shown in fig. 3. Take $E = 2 \times 10^5 \text{ N/mm}^2$. The cross-sectional area of each member is indicated in the figure. (12)

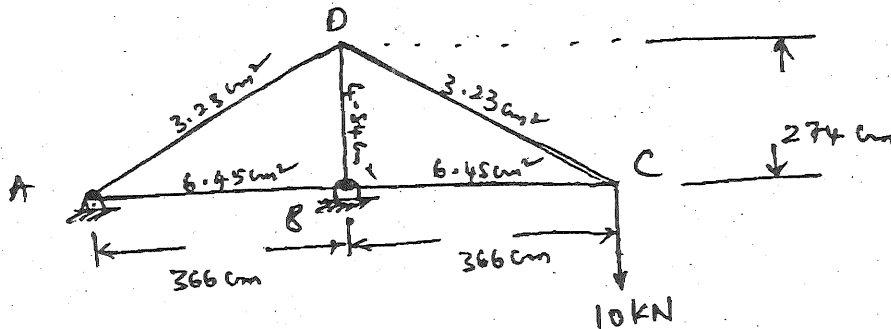

Fig. 3

(10 CE 16)

(10 CE 17)

FOUR YEAR B.Tech. DEGREE EXAMINATION, NOVEMBER 2012

THIRD YEAR/ FIRST SEMESTER

Branch — CE

Paper — R.C.C. STRUCTURAL DESIGN CIRCUITS — I

Time : 3 Hours

Max. Marks : 60

Note : Answer ONE full question from each unit.

IS 456 – 2000 is permitted to use.

All questions carry equal marks.

UNIT - I

1. (a) Explain under reinforced and over reinforced design and which is advisable for designs. (5)
- (b) Design the reinforcement for a reinforced concrete beam 230 mm wide and 350 mm deep of grade M20 to resist an ultimate moment of 75 kN-m using Fe 415 grade steel. (7)

Or

2. A doubly reinforced concrete beam having a rectangular section 250 mm wide and 540 mm overall depth is reinforced with 2 bars of 12 mm diameter in the compression side and 4 bars of 20 mm diameter in the tension side. The effective cover to bars is 40 mm. Using M-20 grade concrete and Fe 415 HYSD bars, estimate the flexural strength of the section using IS-456-2000 code recommendations. (12)

UNIT - II

3. (a) An RC-beam of $b=350$ mm \times $d = 550$ mm effective depth is reinforced with 4 bars of 32 mm diameter out of which two bars are bent up near the support section. Where a factored shear force of 400 kN is acting. Design the suitable shear reinforcement. Use M25 grade concrete and Fe 415 grade steel. (10)
- (b) Define development length and bond. (2)

Or

4. (a) What are the factors affecting shear resistance of a R.C. member? (3)
- (b) Design a dog-lagged staircase (waist slab type) for an office building assuming floor to floor height of 3 m. Width of flight is 1.2 m, landing width = 1.2 m, Adopt a tread of 300 mm and rise of 150 mm. Use M-20 grade concrete and Fe 415 HYSD bars. Live load = 5 kN/m². Assume the landings to be supported only on two edges perpendicular to the risers. (9)

[P.T.O.]

UNIT - III

5. (a) Sketch the typical axial load-moment interaction curve for a column and explain the salient points on it. (3)
- (b) Design the reinforcements in a rectangular column of size 300 mm by 500 mm to support a design ultimate load of 500 kN, together with a factored moment of 200 kN-m. Adopt the value of M20 Grade and Fe 415 Grade steel. (9)

Or

6. (a) What is the maximum length of columns allowed by IS for R.C. columns? Give reasons for specifying their limits. (3)
- (b) Design a circular column to carry an axial load of 2000 kN using helical reinforcement by using M20 grade of concrete and Fe 415 grade steel. (9)

UNIT - IV

7. Design a square footing to transfer a dead load of 1000 kN and an imposed load of 400 kN from a square column 400 mm \times 400 mm (with 16 mm bars). Assuming $f_y = 415$ and $f_{ck} = 20$ N/mm² and safe bearing capacity to be 200 kN/m². (12)

Or

8. Design a circular footing for a circular column of 400 mm diameter carrying an axial load of 1400 kN the bearing capacity of the soil is 200 kN/m². Use 20 Grade concrete and Fe 415 grade steel. (12)

UNIT - V

9. (a) What are the major factors which influence crack widths in flexural members. (3)
- (b) A beam of width 450 mm, depth 750 mm and cover of rein placement 40 mm in reinforced with 3 rods of 40 mm (3780 mm²) diameter. Calculate the crack width when the section is subjected to a bending moment of 490 kN-m. at the points (i) 250 mm below the N.A (ii) in between the spacing of bars under Tension reinforcement (iii) left or right corner of the bottom of beam. (9)

Or

10. A simply supported rectangular beam of effective span 6 m is having breadth 230 mm and effective depth of 450 mm. Tension steel is provided is six numbers of 20 mm and compression steel is two numbers of 16 mm diameter bars. The beam is loaded by a uniformly distributed load of 20 kN/m. Estimate the short term deflection. (12)

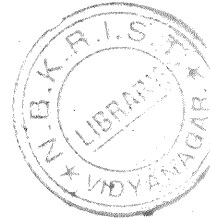

(10 CE 21)

B.Tech. DEGREE EXAMINATION, NOVEMBER 2012

THIRD YEAR/FIRST SEMESTER

Branch - CE

Paper — OPEN CHANNEL HYDRAULICS

Time : 3 Hours

Max. Marks : 60

Answer FIVE questions, choosing ONE question from each Unit.

UNIT - I

1. (a) What do you understand by Open Channel Flow? What is the purpose of providing bed slope in open Channel? (3)
- (b) State the conditions under which Uniform flow and Non-uniform flows are produced?(3)
- (c) Differentiate between Pipe flow and Open Channel flow. (6)

Or

2. (a) Discuss various types of Open Channels. (3)
- (b) What do you understand by 'Hydraulic Mean Radius' and 'Hydraulic Depth'? Give the expression for
 - (i) Rectangular channel
 - (ii) Pipe running full and
 - (iii) Pipe running NOT full. (3)
- (c) Explain the geometric elements of trapezoidal channel section. (6)

UNIT - II

3. (a) Derive the expression for discharge through open channel by Chezy's formula. (6)
- (b) Find the discharge of drainage water through a sewage channel section consisting of vertical walls of 1.2 m wide 0.6 m deep over a semicircular section of radius 0.6m. Take the value of Chezy's constant $C = 60$ and slope of the bed as 1 in 950. (6)

Or

4. (a) What do you understand by most economical channel section? What are the conditions for a rectangular channel of best section? (6)
- (b) A flow of water of 100 liters per second flows down in rectangular flume of width 60 cm having adjustable bottom slope. If the Chezy's constant C is 55, find the bottom slope necessary for uniform flow with a depth of 30 cm. Also find the conveyance K of the flume. (6)

[P.T.O]

UNIT - III

5. (a) Define critical depth. Establish the following criterion for critical flow in an open Channel. (8)

(i) $\frac{Q^2}{g} = \frac{A^3}{T}$

(ii) $\frac{V^2}{g} = \frac{A}{T} = D$

(iii) $F_r = 1$.

- (b) Differentiate between 'Gradually Varied Flow' and 'Rapid Varied Flow' in open channels. (4)

Or

6. (a) What do you understand by Transitions in open channels? (4)
- (b) Define Alternative depths. (3)
- (c) Water flows through a rectangular channel at a uniform depth of 2m having base width of 5 m at a slope of 1 in 1000. It is desired to obtain critical flow in the channel by providing a sharp hump in the bed. Calculate the height of the hump. Take Manning's 'n' as 0.02. (5)

UNIT - IV

7. (a) Distinguish between Gradually Varied Flow and Rapidly Varied Flow. Derive the differential equation for water surface in case of a steady Gradually Varied Flow in prismatic channel. (6)
- (b) Discuss the classifications of flow profiles in open channels. (6)

Or

8. (a) What do you understand by control sections? Discuss its applications with neat sketches. (6)
- (b) A rectangular channel 7.0 m wide has a uniform depth of flow of 2.0m and has a bed slope of 1 in 3000. A weir is constructed at a downstream end of the channel, water surface at a section raised by 0.7 m, determine the water surface slope with respect to horizontal at this section. Assume Manning's n as 0.018. (6)

UNIT - V

9. (a) Determine from first principle the conditions required for the formation of a hydraulic jump in the case of rectangular channel of constant width and calculate loss of head in terms of depth just before and after the jump. (8)
- (b) Define with neat sketches the Surges in open channels. (4)

Or

(10 CE 21)

10. (a) Show that the head loss in a hydraulic jump formed in rectangular channel may be written as $\Delta E = \frac{(V_1 - V_2)^2}{2g(V_1 + V_2)}$. (6)

(b) A rectangular channel carries a flow with a velocity of 0.7m/sec and a depth of 1.5 m. If the discharge is abruptly increased two fold by a sudden lifting of a gate on the upstream, estimate the velocity and height of resulting surge. (6)

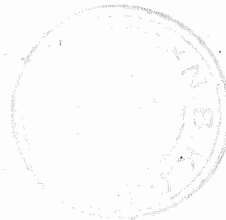

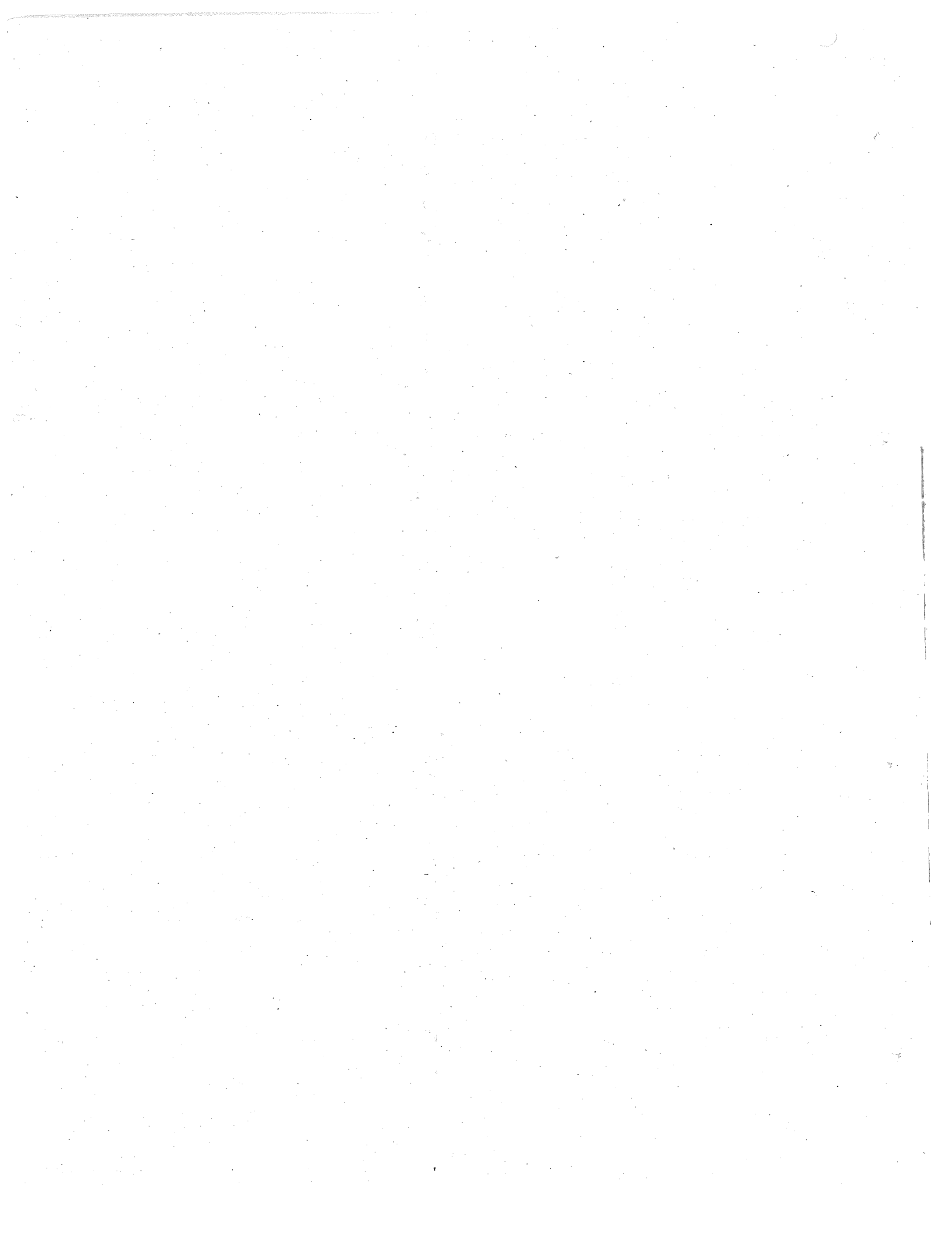

(10 EC 17)

B.Tech. DEGREE EXAMINATION, NOVEMBER 2012

THIRD YEAR/FIRST SEMESTER

Branch - EEE & EICE

Paper — LINEAR IC APPLICATIONS

Time : 3 Hours

Max. Marks : 60

Answer ONE question from each unit.

UNIT - I

1. (a) Draw the pin diagram and schematic symbol of a typical op - amp and explain the function of each pin. (6)
- (b) Derive the output voltage of an op- amp based inverting amplifier. (6)

Or

2. (a) List out the ideal characteristics of an op- amp (4)
- (b) What do you mean by the term "virtual ground"? (4)
- (c) What is a voltage follower? What are its application? (4)

UNIT - II

3. (a) What do you mean by sampling? Explain the basic circuit for sample and hold circuit. (6)
- (b) Draw a circuit using op- amp, which can work as inverting adder and explain how it works. (6)

Or

4. (a) Describe the principle of operation of a precision half wave rectifier with wave forms. (6)
- (b) Explain the operation of log - amplifier. (6)

UNIT - III

5. (a) What is the difference between a basic comparator and the Schmitt trigger? Construct a Schmitt trigger circuit using op - amp and derive the threshold voltages. (6)
- (b) Draw the circuit diagram of Wein bridge Oscillator and derive the expression for frequency of oscillation. (6)

Or

6. (a) Draw and explain the operation of a triangular wave generator. (6)
- (b) What are the conditions to be satisfied by a circuit to produce Oscillations? (6)

[P.T.O]

UNIT - IV

7. (a) With a neat block diagram explain the operation of a fixed voltage Regulator. (6)
- (b) Describe the operation of an IC based negative voltage regulator. (6)

Or

8. (a) Explain Series and Shunt regulators. (6)
- (b) What is a switch mode power supplies? Discuss advantages and disadvantages. (6)

UNIT - V

9. (a) List out various types D/A converters and A/D converters and compare their merits and demerits. (6)
- (b) Give the Schematic circuit of successive approximation A/D converter and explain its operation. (6)

Or

10. (a) Define the following terms with reference to D/A converters. (6)
- (i) Resolution
- (ii) Linearity
- (b) Draw the circuit diagram of a mostly used D/A converter and derive the expression for output voltage for 4- bits. (6)

(10 EE 10)

B.Tech. DEGREE EXAMINATION, NOVEMBER 2012

THIRD YEAR/FIRST SEMESTER

Branch - EEE & ECE

Paper — ELECTRICAL AND ELECTRONIC MEASUREMENTS

Time : 3 Hours

Max. Marks : 60

UNIT - I

1. (a) Explain the theory of Electro dynamometer type Wattmeter and discuss its merits. (6)
- (b) Describe the construction and working of a induction type energy meter. (6)

Or

2. (a) Explain the construction and operation of a rectifier type ammeter. (6)
- (b) List and discuss the important functions of instrument transformers. (6)

UNIT - II

3. (a) Explain Campbell Bridge for measurement of mutual inductance. (6)
- (b) Explain Ammeter- voltmeter method for measurement of resistance. (6)

Or

4. (a) What is a Wein bridge? What are its applications? (6)
- (b) Explain Kelvin Double Bridge method for measurement of resistance. (6)

UNIT - III

5. (a) What are the difference between a dual trace and dual beam oscilloscopes? (6)
- (b) Describe the principle of operation of a sampling oscilloscope. Compare its performance with a storage Oscilloscope. (6)

Or

6. (a) With the help of a block diagram explain the working of Dual trace oscilloscope. (6)
- (b) Write about vertical and Horizontal deflection systems. (6)

UNIT - IV

7. (a) Explain the construction and operation of a true rms reading voltmeter. (6)
- (b) Write typical specifications of an Digital Multimeter used in the laboratory. (6)

Or

8. (a) Explain with the help of a neat diagram, the working of Ramp type digital voltmeter. (6)
- (b) What are the advantages of digital instruments over analog instruments? (3)
- (c) Write short notes on Chopper type micro - voltmeter. (3)

[P.T.O]

UNIT - V

9. (a) A compressive force is applied to a structural member. The strain in 5 micro-strain. Two separate strain gauges are attached to the structural member, One is a nickel wire strain gauge having a gauge factor of - 12.1 and the other in nicrome wire strain gauge having a gauge factor 2. Calculate the value of resistance of the gauges after they are strained. The resistance of strain gauges before being strained in $120\ \Omega$. (6)
- (b) Describe the construction, principle of working and application of Piezo- electric transducers. Derive expressions for voltage and Charge sensitivities. (6)

Or

10. (a) Describe the working and construction of resistance thermometers. Describe the materials used for RTDs, along with their properties. Sketch their typical characteristics. (6)
- (b) A barium titanaete has the dimensions of $5\text{mm} \times 5\text{mm} \times 1.25\text{mm}$. The force acting on it is 5 N. The charge sensitivity of barium titanate is 150 PC/N and its permittivity is $12.5 \times 10^{-9}\text{ F/M}$. If the modulus of elasticity of barium titanate in $12 \times 10^6\text{ N/M}^2$, calculate the strain. (6)

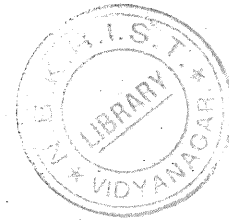

(10 EE 11)

B.Tech. DEGREE EXAMINATION, NOVEMBER 2012

THIRD YEAR/FIRST SEMESTER

Branch - EEE

Paper — POWER SYSTEMS - I

Time : 3 Hours

Max. Marks : 60

Answer ONE question choosing from each Unit.

UNIT - I

1. (a) Comparison between single phase and 3-phase 3-wire systems. (6)
- (b) Write about types of secondary distribution systems. (6)

Or

2. (a) Derive the expression for 3-phase 4 wire system primary distribution. (6)
- (b) Explain at AC-distribution fed at one end and at both ends at AC system distribution. (6)

UNIT - II

3. (a) Derive the expressions for capacitance calculation at transmission line. (6)
- (b) Write about Lorentz-description at phenomenon. (6)

Or

4. (a) What are factors affecting corona? (6)
- (b) Derive the expressions for bundled conductor-effect at earth on capacitance. (6)

UNIT - III

5. (a) Write short notes on skin and proximity effects. (6)
- (b) Write about effects of resistance of solid conductors. (6)

Or

6. (a) Explain the factors affecting corona. (6)
- (b) Explain the factors critical disruptive voltage and visual critical voltage (with necessary equations). (6)

[P.T.O]

UNIT - IV

7. (a) Explain calculation at Sag for equal and unequal supports at over head transmission line. (6)
(b) Explain loading on the conductors in an over head line with necessary equations. (6)

Or

8. (a) Explain the potential distribution over a string at insulators at over head line with related equations. (6)
(b) Derive the expressions for methods of equalizing the potential and string efficiency at over head transmission insulator. (6)

UNIT - V

9. (a) Explain about insulating materials for EHV voltage cables. (6)
(b) Explain classification of cables with neat diagrams. (6)

Or

10. (a) Explain capacitance at three core betted cable, with neat diagrams. (6)
(b) Explain about breakdown cubles and cable installation. (6)



(10 EE 09)

B.Tech. DEGREE EXAMINATION, NOVEMBER 2012

THIRD YEAR/FIRST SEMESTER

Branch - EEE, ECE and EICE

Paper - LINEAR CONTROL SYSTEMS



Time : 3 Hours

Max. Marks : 60

Answer any ONE question from each Unit.

UNIT - I

1. (a) Explain open loop and closed loop control system with an example. (3)
- (b) Determine C/R ratio at the block diagram using block diagram reduction technique shown below. (9)

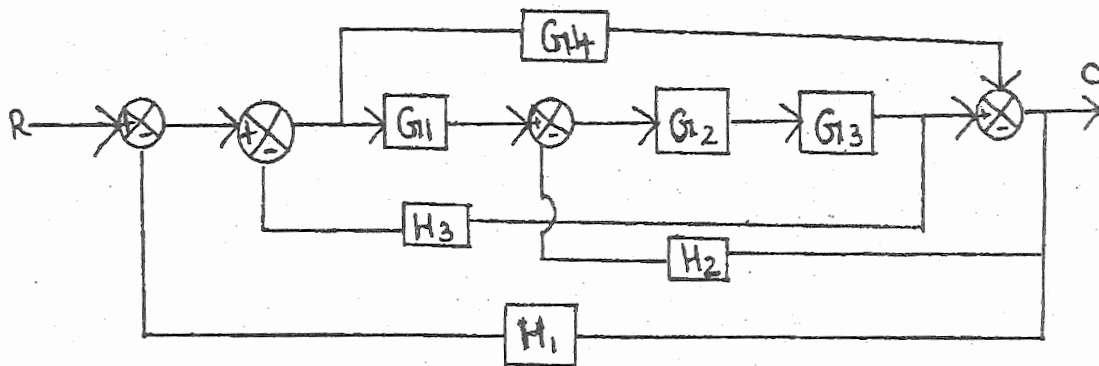

Or

2. (a) Explain Masson's gain formulae with neat steps. (3)
- (b) Obtain the transfer function of S.F.G. shown in Fig. using Masson's gain formula. (9)

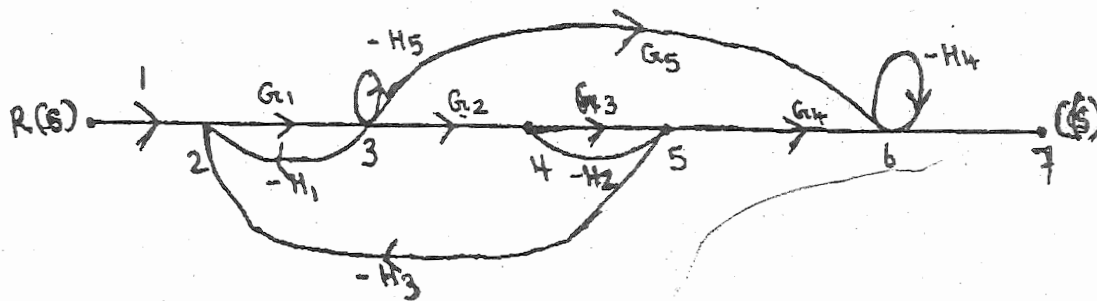

[P.T.O]

UNIT - II

3. (a) Derive transfer function of field controlled DC servo motor. (5)
- (b) Draw :
- (i) Force - voltage
 - (ii) Force - current analogous circuit for the system shown below, also write differential equation and electrical equations.

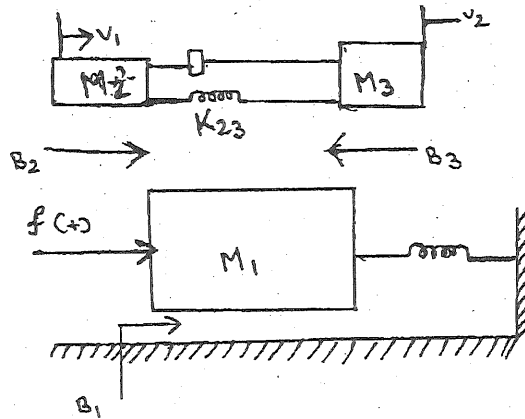

Or

4. (a) Explain working of synchro pair and mention its applications.
- (b) Write the simultaneous differential equations for the translational mechanical system shown in fig and hence find $X_1(s)$.

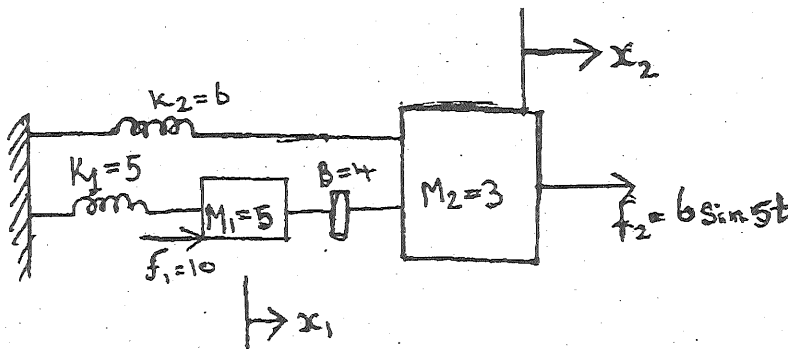

UNIT - III

5. (a) Derive the step response of a first order system. Also find the steady state error. (4)
- (b) Explain in detail the time response specifications of second order system. (8)

Or

6. (a) Derive expressions for steady state error at type 0, type 1 and type 2 systems excited by unit step input. (6)
- (b) Explain the effect of P, I, PI, PD and PID controllers action on the performance of a system. (6)

(10 EE 09)

UNIT - IV

7. (a) A unity negative feedback control system has an open loop transfer function consisting of two poles, two zeros and a variable gain k . The zeros are located at -2 and -1 and the poles at 0.1 and $+1$. Using Routh stability criterion, determine the range of values of k for which the closed loop system has 0, 1 or 2 poles in the right half S-plane. (8)
- (b) Explain gain margin and phase margin. (4)

Or

8. Sketch the root locus for the given equation $G(s) \cdot H(s) = \frac{k}{s(s+4)(s^2+2s+5)}$ find the range of k values for which the system is stable.

UNIT - V

9. (a) Sketch the Bode plot for the T.F. $G(s) = \frac{k e^{-0.5s}}{s(s+2)(1+0.35s)}$. Find k value for the source cross over frequencies ω_0 to 5 rad/sec. (8)
- (b) Draw the circuit of a phase-lag network and derive its T.F. (4)

Or

10. (a) Draw the polar plot for the following T.F. $\frac{k}{S(1+ST)}$. (6)
- (b) Design a lead compensation with $G(s) = \frac{k_v}{s(s+1)}$ it is specified that $k_v = 12 \text{ sec}^{-1}$ and phase margin is equal to 40° . (6)

(10 EC 14)

B.Tech. DEGREE EXAMINATION, NOVEMBER 2012

THIRD YEAR/FIRST SEMESTER

Branch - EEE, ECE & EICE

Paper — PULSE & DIGITAL CIRCUITS

Time : 3 Hours

Max. Marks : 60

Answer any ONE question from each Unit.

UNIT - I

1. (a) A 10 Hz symmetrical square wave whose peak-to-peak amplitude is 2V is impressed up on a high pass RC circuit whose lower 3db frequency is 5Hz. Calculate and sketch the output waveform. What is the peak-to-peak amplitude of the output waveform? (6)
- (b) Explain why simple resistance alternator is to be compensated. Draw the circuit at compensated alternator and explain. (6)

Or

2. (a) Explain the operation of negative clamper circuit using diode. (4)
- (b) State and prove clamping circuit theorem with relevant circuit and waveforms. (8)

UNIT - II

3. (a) Explain the transistor switching times. Define rise time, fall time, delay time and storage time of transistor. (6)
- (b) Design the transistor switch (Inverter) for the following specifications. $V_{in} = \pm 5V$ square wave, $V_{cc} = 15V$, $I_C = 2mA$, $h_{FE} = 50$. Assume Si transistor. (6)

Or

4. (a) Explain the operation at Astable Multivibrator and derive the expression for time-period of output square wave. (6)
- (b) Design collector coupled fixed-bias Bistable multivibrator to operate from $\pm 6V$ supply. Given $I_C(\text{set}) = 1mA$, $h_{FE} = 35$. Assume Si transistor. (6)

UNIT - III

5. (a) Explain briefly the different methods of generating time-base waveform. (6)
- (b) With the circuit diagram explain current time base generator. (6)

Or

6. (a) Explain Synchronization using monostable symmetrical signals. (6)
- (b) Explain how sine wave frequency division is obtained with sweep circuit. (6)

[P.T.O]

UNIT - IV

7. (a) Explain the basic operating principle at sampling gate. (6)
(b) Explain the unidirectional sampling gates. (6)

Or

8. (a) Explain the bidirectional sampling gates. (6)
(b) Explain any two applications of 555 timer when it is used in mono-stable mode. (6)

UNIT - V

9. Draw the circuit at 3- input AND gate using diodes and resistors and explain with truth table. (12)

Or

10. Draw the circuit diagram of NAND gate using TTL logic and explain. (12)



(10 EE 12)

B.Tech. DEGREE EXAMINATION, NOVEMBER 2012

THIRD YEAR/FIRST SEMESTER

Branch - EEE

Paper — ELECTRO MECHANICAL ENERGY CONVERSION - III

Time : 3 Hours

Max. Marks : 60

Answer FIVE questions, choosing One questions from each unit.

UNIT - I

1. (a) With a neat diagram, explain the main parts and working of a wind electric system. (8)
- (b) Explain Synchronous types of alternators. (4)

Or

2. (a) Calculate the speed and open-circuit line and phase voltage of a 4-pole, 3-phase, 50 Hz, star-connected alternator with 24 slots and 30 conductors per slot. The Flux per pole is 0.0496 wb and is sinusoidally distributed. (6)
- (b) What are the advantages of using stationary armature over rotating armature in Synchronous machine? (6)

UNIT - II

3. (a) Write a note on distributed generation. (6)
- (b) Explain about pole machines of two reaction theory. (6)

Or

4. (a) Derive the expression for power output of cylindrical alternators. (6)
- (b) Derive the expression for power output of salient pole alternator. (6)

UNIT - III

5. (a) Explain the conditions for parallel operation of alternator. (6)
- (b) Explain the parallel operation of Synchronization alternator. (6)

Or

6. (a) Explain the load sharing at parallel alternator. (6)
- (b) Derive the expression for operation on infinite bus-bar effect of change at excitation. (6)

UNIT - IV

7. (a) Derive the expression for theory of operation for Synchronous motor. (6)
- (b) Derive the expression for current, voltage, power of phasor Synchronous motor. (6)

Or

8. (a) What are the advantages and disadvantages of Synchronous motor? (6)
- (b) Derive the expression for Synchronous motor power starts methods. (6)

[P.T.O]

UNIT - V

9. (a) Explain the principle of operation of stepper motor. (6)
(b) Give good explanation at different types of stepper motor's principle operations. (6)

Or

10. (a) Explain principle and working of Brushless DC motor. (6)
(b) Explain principle and control of stepper motor. (6)

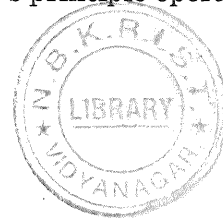

(10 EC 13)

B.Tech. DEGREE EXAMINATION, NOVEMBER 2012

THIRD YEAR/FIRST SEMESTER

Branch - ECE

Paper — DIGITAL COMMUNICATIONS

Time : 3 Hours

Max. Marks : 60

Answer ONE question from each unit.

UNIT - I

1. (a) Explain how PWM signals are generated. (6)
- (b) Explain how PPM signals are generated. (6)

Or

2. (a) Classify channels. Explain the mathematical of any two communication channels. (4)
- (b) Explain Binary symmetric channel and Gaussian channel with their mathematical models. (8)

UNIT - II

3. (a) Explain about delta modulation and demodulator with block diagram. (6)
- (b) Explain a non- uniform quantization process. (6)

Or

4. (a) Write notes on temporal waveform coding. (6)
- (b) Explain of comparison of TDM and FDM. (6)

UNIT - III

5. (a) Explain characterization of band- limited channels. (6)
- (b) Explain the design of band - limited signals for no inter symbol interference (ISI). (6)

Or

6. (a) Derive the expression for bit errors probability due to a matched filter. (8)
- (b) Explain about Inter symbol interference and Eye diagrams. (4)

[P.T.O]

UNIT - IV

7. (a) Derive the bit error probability due to coherent ASK, PSK and FSK systems. (8)
(b) Compare the performance of ASK, PSK and FSK systems. (4)

Or

8. (a) Derive the bit error probability due to QPSK receiver. (6)
(b) Compare the performance of QPSK receiver with that of PSK receiver. (6)

UNIT - V

9. (a) Explain linear block codes, with required diagrams. (6)
(b) Explain coding and decoding of matrix description. (6)

Or

10. (a) Explain Encoding using shift register with neat diagrams. (6)
(b) Explain and derive Burst and random error correcting codes, with related equations. (6)

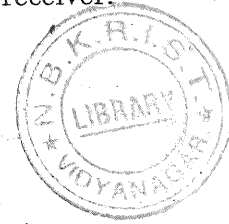

(10 EC 11)

THREE YEAR B.Tech. DEGREE EXAMINATION, NOVEMBER 2012

FIRST SEMESTER

Branch - ECE

Paper — ANTENNA AND WAVE PROPAGATION

Time : 3 Hours

Max. Marks : 60

Answer One question from each unit.

UNIT - I

1. Write short notes on :

- (a) Distortionless lines
- (b) Standing waves
- (c) Reflection coefficient
- (d) Propagation constant.

Or

2. A 20m long lossless transmission line with $Z_0 = 100 \Omega$ operating at 2MHz is terminated with a load $Z_R = 60 + j40 \Omega$. If $V_p = 0.6 V_0$ on the line. Find :

- (a) The reflection coefficient
- (b) The SWR
- (c) The input impedance.

UNIT - II

3. (a) Define directivity of an antenna and show that the directivity of an electric current element is 1.5. (6)
- (b) What factors govern the selection of the feed point of a dipole antenna? How do current feed and voltage feed differ? (6)

Or

4. (a) Explain the significance of effective area of an antenna and compute the effective area of a half-wave dipole. (6)
- (b) What is the effective area of an half wave dipole operating at 600 MHz.

UNIT - III

5. (a) Explain the different methods of Array synthesis. (6)
- (b) Draw the radiation pattern of a 4 element uniform linear array consists of dipoles spaced between two elements is $\lambda/2$ and fed with equal amplitude and successive phase shift of 90° current sources. (6)

Or

[P.T.O]

6. (a) Explain the principle of super directive arrays. (6)
(b) Find the beam width of end fire array and compare it with broadside array. (6)

UNIT - IV

7. (a) Explain the effect of curvature of earth on wave propagation. (6)
(b) What is Faraday's rotation? Explain clearly the Faraday's rotation phenomenon in the Ionosphere. (6)

Or

8. (a) Describe in detail the effect of earth's atmosphere in space wave propagation. (6)
(b) Derive the Friss's transmission formula. (6)

UNIT - V

9. (a) Explain the phenomena of refraction and reflection of sky wave by ionosphere. (6)
(b) Obtain an expression for the critical frequency of an ionosphere layer. (6)

Or

10. Explain the following terms :

- (a) Skip distance
(b) MUF
(c) Virtual height
(d) Critical frequency.



(12)

(10 EC 12)

B.Tech. DEGREE EXAMINATION, NOVEMBER 2012

THIRD YEAR/FIRST SEMESTER

Branch - ECE

Paper — ANALOG IC APPLICATIONS

Time : 3 Hours

Max. Marks : 60

Answer any ONE question from each Unit.

UNIT - I

1. (a) Explain the operation of an op- amp with the help of block diagram. (6)
- (b) Explain AC characteristics of an op- amp. (6)

Or

2. (a) Explain the operation of a non - inverting mode op- amp. (6)
- (b) Why voltage follower is also called as a buffer and explain the advantages of voltage follower? (6)

UNIT - II

3. (a) Explain the operation of an Antilog Amplifier. (6)
- (b) What is meant by precision diode and explain the operation of precision full wave Rectifier? (6)

Or

4. (a) Explain the operation I to V converter using both inverting and Non - inverting configurations. (6)
- (b) Explain the operation of a differential amplifier using three op- amp and also mention its characteristics. (6)

UNIT - III

5. (a) Explain any two applications of comparator circuit using op- amp. (6)
- (b) Explain the operation of RC phase Schmidt oscillator and derive the expression for frequency of oscillations. (6)

Or

6. (a) Explain the operation a voltage controlled oscillator using a functional diagram. (6)
- (b) Explain operation of a regenerative comparactor and also write the equations for V_{ut} and V_{lt} . (6)

[P.T.O]

UNIT - IV

7. (a) Explain the basic operation of PLL with the help of block diagram. (6)
- (b) Write about application of a PLL. (6)
- (i) AM/FM demodulator
- (ii) Frequency divider.

Or

8. (a) Explain the operation of a switching regulator. (6)
- (b) Explain the operation of fixed voltage regulator. (6)

UNIT - V

9. (a) List out advantages of an active filter over passive filters. (6)
- (b) Obtain the transfer function of a high pass filter. (6)

Or

10. (a) Design a Band Pass with a $f_L = 200\text{HZ}$ and $f_H = 2\text{KHZ}$ and pass band gain of 4. Find the Q - factor also. (6)
- (b) Derive the transfer function of a 2nd - order low pass filter. (6)



(10 ME 11)

FOUR YEAR B.Tech. DEGREE EXAMINATION, NOVEMBER 2012

THIRD YEAR EXAMINATION

FIRST SEMESTER

Branch – Mechanical Engineering

Paper — APPLIED THERMODYNAMICS – II

Time : 3 Hours

Max. Marks : 60

Answer any ONE question from each Unit.

Use of Refrigeration and air-conditioning charts are permitted.

UNIT – I

1. (a) Explain three methods usually adopted to control the quantity of air delivered by reciprocating air compressor and discuss its merits and demerits. (4)
- (b) A single stage single acting air compressor delivers 0.6 kg of air per minute at 6 bar. The temperature and pressure at the end of suction stroke are 30°C and 1 bar. The bore and the stroke of the compressor are 100 mm and 150 mm respectively. The clearance is 5% of the swept volume. Assume index of compression and expansion $n = 1.3$. Find (8)
- (i) Volumetric efficiency of the compressor
- (ii) Power required if the mechanical efficiency is 85%
- (iii) Speed of the compressor.

Or

2. (a) A single stage double acting air compressor is required to deliver 14 m³ of per minute measured at 1.013 bar and 15°C. The delivery pressure is 7 bar and the speed 300 rpm. Take the clearance volume as 5% of the swept volume with compression and expansion index of $n = 1.3$, calculate (8)
- (i) Swept volume of the cylinder
- (ii) Delivery temperature
- (iii) Indicated power.
- (b) Derive an expression for volumetric efficiency of a single stage reciprocating air compressor. (4)

[P.T.O]

UNIT - II

3. (a) A centrifugal compressor is desired to have a total pressure ratio of the compressor impeller is 30 cm in diameter. The axial velocity at inlet is 130 m/s and mass flow is 10 kg/s. The velocity in the delivery duct is 115 m/s. The tip speed of the impeller is 450 m/s and runs at 16000 rpm with total head isentropic efficiency of 78% and pressure coefficient of 0.72. The ambient conditions are 1.013 bar and 15°C. Calculate : (8)
- (i) Static pressure ratio
- (ii) Static pressure and temperature at inlet and outlet of compressor.
- (b) A compressor operates at standard sea level air with a pressure ratio of 5 and an air - consumption of 35 kg/s at isentropic efficiency of 86%, Calculate the work done per kg of air power required to drive the compressor. (4)

Or

4. (a) Compare axial and rotary compressors. (6)
- (b) A multistage axial compressor is required for compressing air at 293 K through a pressure ratio of 5 to 1. Each stage is to be 50% reaction and the mean blade speed is 275 m/s, flow coefficient 0.5 and stage loading factor 0.3 are taken for simplicity as constant for all stages.
- Determine the flow angles and number of stages required if the stage efficiency is 88.8%. Assume $C_p = 1.005 \text{ kJ/kg K}$ and $\gamma = 1.4$ for air. (6)

UNIT - III

5. (a) In a gas turbine plant, air is compressed from 1 bar and 15°C through a pressure ratio 4 : 1. It is then heated to 650°C in combustion chamber and expanded to 1 bar in a turbine. Calculate efficiency and work ratio, if perfect heat exchanger is used. Assume isentropic efficiency of turbine and compressor as 85% respectively. (6)
- (b) What are the disadvantages of a closed gas turbine over open cycle gas turbine? What are the desirable properties of fluid suitable for closed cycle operation? (6)

Or

6. (a) A gas turbine takes in air at 27°C and 1 bar. The pressure ratio is 4 and the maximum temperature in the cycle is 560°C. The compressor and turbine efficiencies are 0.83 and 0.85 respectively. Determine the overall efficiency if the regenerator effectiveness is 0.75. (6)
- (b) Explain with a simple sketch, construction and working of a turbojet engine. (6)

(10 ME 11)

UNIT - IV

7. (a) What are the factors which affects the choice of refrigerants, explain them briefly. (4)
- (b) A refrigeration plant using R 12 as a refrigerant is used for producing ice which has an output of 10 tons of ice per day water at 35°C to ice at -5°C . At least 10°C temperature difference is required for better heat transfer at condenser and evaporator, Assuming simple saturation cycle, determine :
- (i) Refrigeration capacity of the plant, mass flow of refrigerant and discharge temperature
- (ii) Determine the dimensions of the compressor if its volume efficiency is 90% and $L/D = 1$ running at 1400 rpm. (8)

Or

8. (a) An ammonia refrigerator operates between evaporating and condensing temperatures of -16°C and 50°C respectively. The vapor is dry saturated at compressor inlet and the compression process is isentropic and there is no under cooling of the condensate. Calculate :
- (i) Refrigerating effect per kg
- (ii) Mass flow rate and power input per kW of refrigeration
- (iii) COP. (6)
- (b) Explain with a neat compact diagram, working of a lithium bromide water adsorption refrigeration system. (6)

UNIT - V

9. (a) Explain with a neat sketch, working of a summer air-conditioning system. (4)
- (b) Air flowing at a rate of $100 \text{ m}^3/\text{min}$ at 40°C DBT and 50% RH is mixed with another stream flowing at the rate of $20 \text{ m}^3/\text{min}$ at 26°C DBT and 50% RH. The mixture flows over a cooling coil whose ADP temperature is 10°C and bypass factor is 0.2. Find DBT and RH of air leaving the coil. If air is supplied to the air conditioned room where DBT is 26°C and RH of 50% are maintained, estimate :
- (i) Room sensible heat factor
- (ii) Cooling capacity in tones of refrigeration. (8)

Or

(10 ME 11)
[P.T.O.]

10. A big shop is air-conditioned for sensible load of 58.15 kW and latent load of 14.55 kW. The inside design conditions are 25°C DBT and 50% RH and outside design conditions are 40°C DE'f and 27°C WET. 70 m³/min fresh air is supplied to the shop. Determine :

- (a) Ventilation load
- (b) Total load taken up by the plant
- (c) Effective sensible heat factor
- (d) Apparatus dew point
- (e) Condition of air entering and leaving the apparatus. (by pass factor is 0.15) (12)



(10 SH 15)

FOUR YEAR B.Tech. DEGREE EXAMINATION, NOVEMBER 2012

THIRD YEAR/FIRST SEMESTER

Branch – Mechanical Engineering

Paper — ECONOMICS AND ACCOUNTANCY

Time : 3 Hours

Max. Marks : 60

Part A and Part B are to be answered separately

Answer any THREE Questions from each Part.

PART - A

(ECONOMICS)

(Marks : 30 marks)

UNIT - I

1. (a) What are the determinants of demand?
(b) Define elasticity of demand. Explain the income elasticity of demand.

Or

2. (a) What is Marginal Utility? Explain its importance in economics.
(b) Explain the law of demand and state its assumptions.

UNIT - II

3. What are returns to scale? How do they arise?

Or

4. A coastal ship can carry a maximum of 1,00,000 passengers per month at a fare of Rs. 850/- Variable cost per passenger is Rs. 100/- while the fixed costs are Rs. 75,00,000/- per month. Find the break even quantity and sales volume. If the company sets a profit target of Rs. 75,00,000/-, what will be its breakeven point?

UNIT - III

5. Explain the different types of competitive situations that may be possible in a market.

Or

6. (a) Describe how output is determined under perfect competition market.
(b) What is imperfect competition? Describe how price is determined under imperfect competition.

[P.T.O]

PART - B
(ACCOUNTANCY)
(Marks : 30 marks)

UNIT - IV

7. What is a joint stock company? Explain the advantages, limitations, and formation of a joint stock company.

Or

8. (a) What are the differences between shares and debentures?
(b) Differentiate between sole proprietorship and partnership companies. Mention their advantages and limitation.

UNIT - V

9. (a) Distinguish between
(i) Cash book and ledger and
(ii) Trial balance and balance sheet.
(b) Distinguish between capital and revenue items. Explain the significance of such distinctions.



Or

10. The following particulars belong to a firm for the accounting year ending Dec. 31, 2011. Prepare
(a) Trading account
(b) Profit and loss A/c
(c) Balance sheet.

	Rs.
Opening Stock	5,000
Sales	30,000
Carriage	500
Stock on closing data	4,000
Wages	500
Sold goods returned	2,000
Material purchased	8,000
Discount	500
Commission	500
Office expenses	2,400

(10 SH 15)

	Rs.
Rent paid	500
Bank charges	100
Capital	30,000
Loan	5,000
Trade debtors	3,000
Trade creditors	1,000
Machines and Equipment	25,000
Office furniture	5,000
Cash in Bank	15,000

UNIT - VI

11. (a) Define working capital and state the different sources of working capital.
 (b) What is capital budgeting? Explain the need for capital budgeting.

Or

12. (a) What is costing? Explain the methods of costing.
 (b) How to estimate working capital requirement? Explain with example.

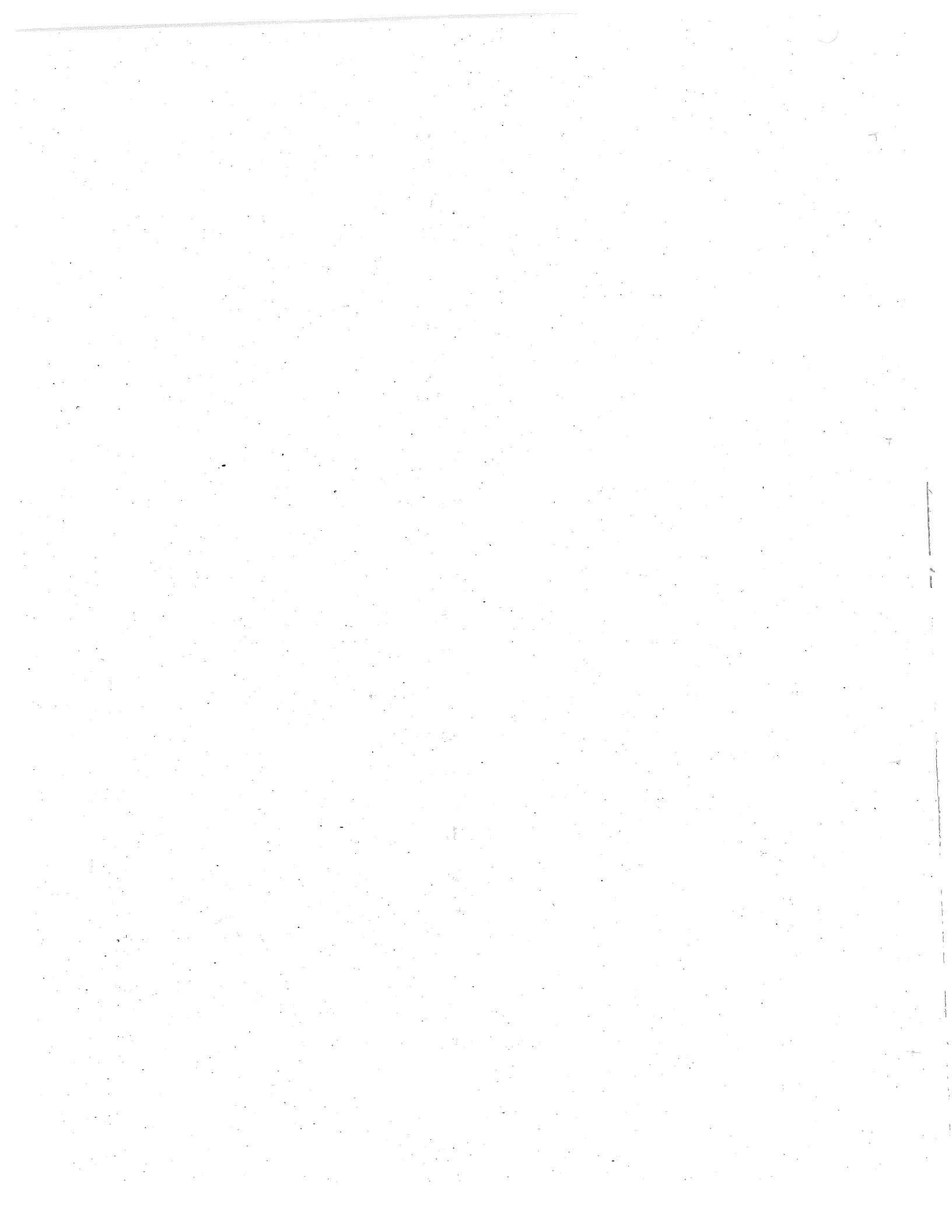

(10 ME 12)

FOUR YEAR B.Tech. DEGREE EXAMINATION, NOVEMBER 2012

THIRD YEAR/FIRST SEMESTER

Branch – Mechanical Engineering

Paper — INDUSTRIAL ENGINEERING AND MANAGEMENT

Time : 3 Hours

Max. Marks : 60

Answer ONE question from each Unit.

Use of statistical tables is permitted.

UNIT – I

1. (a) Explain the principles of scientific management. (4)
(b) Discuss the functions of management. (8)

Or

2. (a) Explain the contributions of Fayol to management. (6)
(b) Explain the principles of organization. (6)

UNIT – II

3. (a) Explain the advantages and disadvantages of urban and rural locations. (6)
(b) State the factors to be considered for designing a plant layout. On this basis, compare process layout and product layout. (6)

Or

4. (a) What are the objectives and advantages of scientific layout? (6)
(b) What are the various factors that will be considered for selection of material handling equipment for internal transportation? (6)

UNIT – III

5. (a) State and explain the principles of production planning and control. (6)
(b) A department store analyst is interested in using the change in price of sugar in a given month to predict the change in price of candy the following month. The store keeper chooses a widely watched exchange and observes the following monthly sequence of prices (not price change). Find the estimated regression line. (6)

Sugar price : 80 82 85 81 80 80 80 84 88 89 90 88 84

Candy price month : 105 100 105 114 107 105 104 105 110 117 120 121 118

Or

[P.T.O]

6. (a) Describe the follow up or control phase of production planning and control. (6)
(b) Forecast the demand for the following series by exponential smoothing method.
(Take $\alpha = 0.3$ and initial forecast = 10). (6)

Actual :	1	2	3	4	5	6	7	8	9	10
Demand :	10	12	8	11	9	10	15	14	16	15

UNIT - IV

7. (a) Describe the basic procedure to be followed in adopting work study techniques for sound results. (6)
(b) Explain the nature and use of operation chart. (6)

Or

8. (a) What is performance rating? Explain its importance in determining the standard time. (6)
(b) Describe PMT system of work measurement and give its advantages and disadvantages over stop watch time study. (6)

UNIT - V

9. (a) Explain the steps to be taken to control accidents. (6)
(b) Explain the point method of job evaluation. (6)

Or

10. (a) Describe briefly the Factories Act. (6)
(b) Explain the following incentive plans :
(i) Rowan plan.
(ii) Taylor's Differential piece rate plan. (6)



(10 ME 12)

B.Tech. DEGREE EXAMINATION, NOVEMBER 2012

THIRD YEAR/FIRST SEMESTER

Branch - ME

Paper - ELECTRICAL ENGINEERING

Time : 3 Hours

Max. Marks : 60

Answer any ONE question from each Unit.

UNIT - I

1. (a) Explain series, parallel and series parallel circuits. (6)
- (b) Use Mesh analysis to determine the three mesh currents in the circuit of Fig. 1 (6)

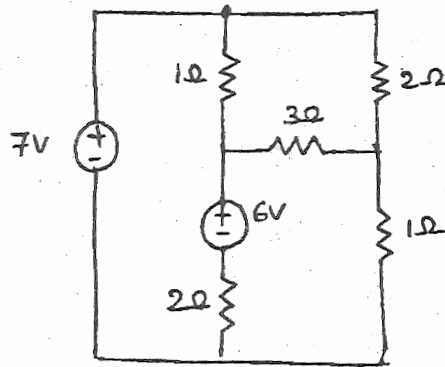

Fig. (1)

Or

2. (a) Explain the behaviour of resistance, Inductance and capacitance to sinusoidal excitation voltage in single phase circuits. (6)
- (b) Use Nodal analysis to determine the current i_x in the circuit of Fig.2 (6)

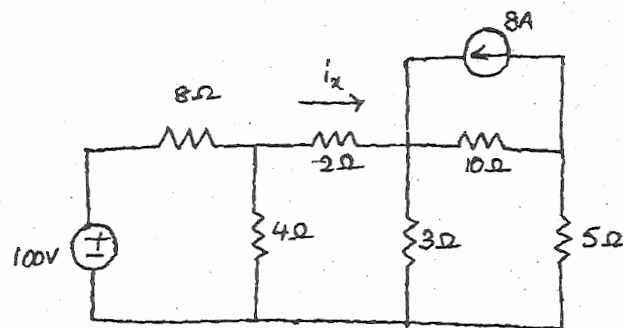

Fig. (2)

UNIT - II

3. (a) Explain the working of DC generator with a neat sketch. (6)
- (b) A 10 kW, 250 V d.c, 6 pole shunt generator runs at 1000 rpms when delivering full load, the armature has 534 lap connected conductors full load Cu losses 0.64 kW. The total brush drop is 1 V. Determine the flux per pole. Neglect shunt current. (6)

Or

4. (a) Explain the types of generators with relevant diagrams. (6)
- (b) A 4-pole, dc shunt generator with a shunt field resistance of 100Ω and an armature resistance of 1Ω has 378 wave-connected conductors in its armature. The flux per pole is 0.02 wb. If a load resistance of 10Ω is connected across the armature terminals and the generator is driven at 1000 rpm. Calculate the power absorbed by the load. (6)

UNIT - III

5. (a) Explain the characteristics of different types of motor. (6)
- (b) A 460 V series motor runs at 500 rpm taking a current of 40 A. Calculate the speed and percentage change in torque if the load is reduced so that the motor is taking 30 A. Total resistance of the armature and field circuits is 0.8Ω . Assume flux is proportional to the field current. (6)

Or

6. (a) What are the types of dc motor starters and explain any one type? (6)
- (b) Explain the losses in motor and derive the expression of efficiency. (6)

UNIT - IV

7. (a) Explain the principle of operation of a Transformer. (6)
- (b) 1- ϕ transformer has 400 primary and 1000 secondary turns. The net cross-sectional area of the core is 60 cm^2 . If the primary winding be connected to 50 Hz supply at 520 V, calculate
- (i) The peak value of flux density in the core
- (ii) The voltage induced in the secondary winding. (6)

Or

8. (a) Draw the Equivalent circuit of a transformer and explain it. (6)
- (b) A 100 kVA transformer has 400 turns on the primary and 80 turns on the secondary. The primary and secondary resistances are 0.3Ω and 0.01Ω respectively and the corresponding leakage reactances are 1.1 and 0.035Ω respectively. The supply voltage is 2200 V. (6)

Calculate :

- (i) Equivalent impedance referred to primary and
- (ii) The voltage regulation and the secondary terminal voltage for full load having a power factor of 0.8 leading.

(10 EE 34)

UNIT - V

9. (a) Draw and explain slip-torque characteristics of an induction motor. (6)
- (b) A 3- ϕ induction motor is wound for 4-pole and is supplied from 50 Hz system. Calculate :
- (i) The synchronous speed
- (ii) Rotor speed, when slip is 4%
- (iii) Rotor frequency when rotor runs at 600 rpm. (6)

Or

10. (a) Explain the principle of operation of 1- ϕ induction motors. (6)
- (b) Explain why 1- ϕ induction motor fails to start. Suggest few methods employed for making it self start. (6)

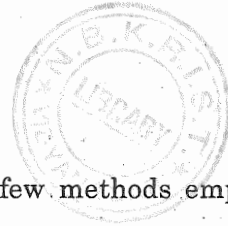

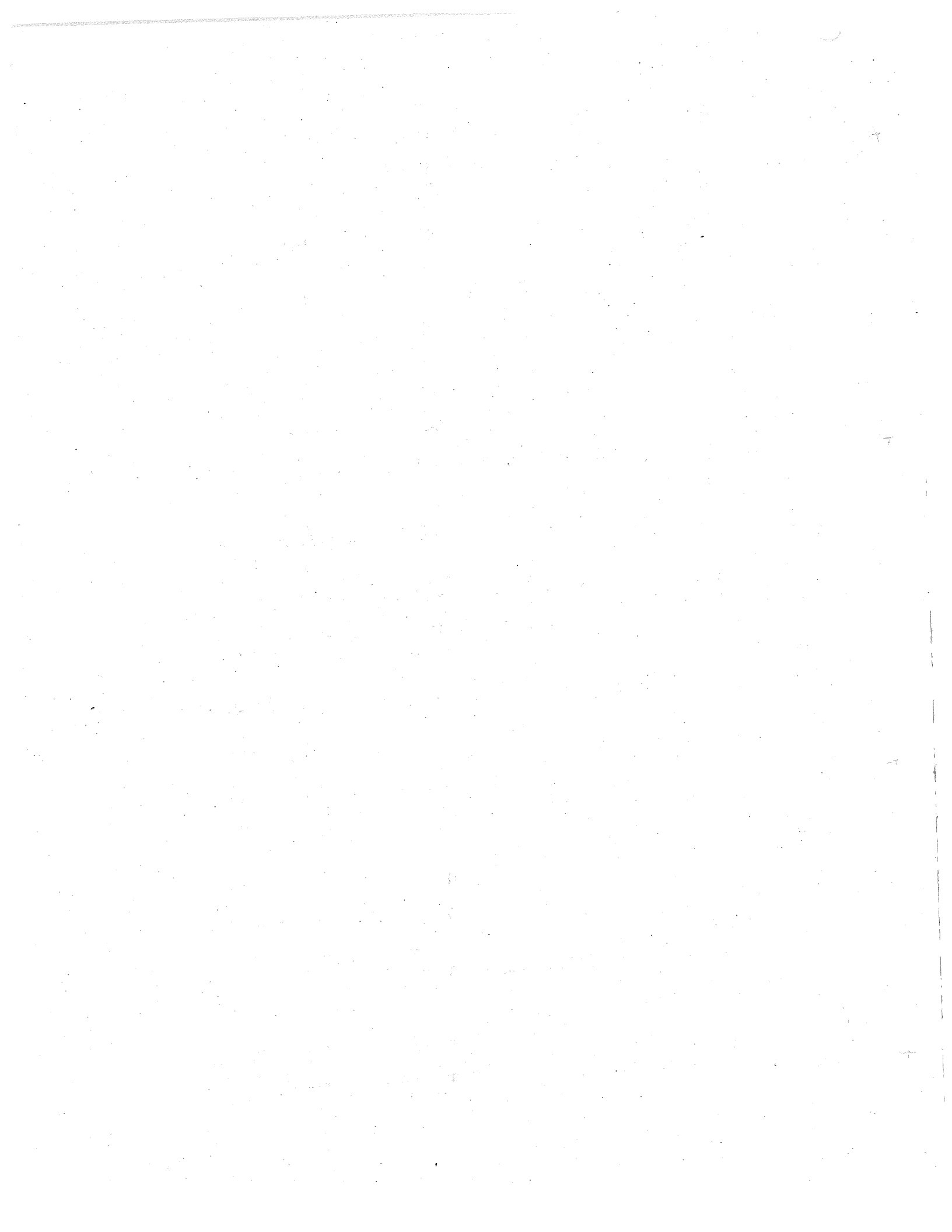

(10 EC 15)

B.Tech. DEGREE EXAMINATION, NOVEMBER 2012

FIRST SEMESTER

Branch - ME

Paper — ELECTRONICS ENGINEERING

Time : 3 Hours

Max. Marks : 60

Answer FIVE questions, choosing One question from each Unit.

All questions carry equal marks.

UNIT - I

1. (a) Draw and explain V-I characteristics of SCR. (6)
- (b) (i) Explain "majority and minority carriers" in a Semiconductor. (6)
- (ii) Explain the formation of depletion region in a PN junction. (6)

Or

2. (a) Draw the circuit diagram of a half wave rectifier and explain its operation. Derive an expression for I_{dc} and I_{rms} for half wave rectifier. (6)
- (b) Compare half-wave and full - wave rectifier in all aspects. (6)

UNIT - II

3. (a) Explain the need for biasing a transistor. (6)
- (b) Explain clearly with suitable examples why bias stabilization is essential for an amplifier using a BJT. (6)

Or

4. (a) Draw the output static characteristics of a BJT in CE configuration and justify the same. Discuss the different region of operation. (6)
- (b) Explain the characteristics of a JFET. (6)

UNIT - III

5. (a) Describe the construction of phase shift oscillator and explain its working. (6)
- (b) Derive the expression for the frequency of oscillations and the minimum gain required for restrained oscillations of the phase shift oscillator. (6)

Or

6. (a) Draw the circuit of colpitts oscillator and explain the principle of operation. (8)
- (b) Draw the circuit diagram of Hartley oscillator and briefly explain its operation. (4)

[P.T.O]

UNIT - IV

7. (a) Explain how frequency and amplitude of the signal can be measured using CRO. (6)
(b) Describe the working of an electronic multimeter with help of block diagram. (6)

Or

8. (a) Explain the operation of integrating type DVM. (6)
(b) Describe the applications of CRO. (6)



UNIT - V

9. Draw the block diagram of 8085 microprocessor and explain the various elements available. (12)

Or

10. Write short notes on the following :

- (a) Instruction set and simple assemble language programming (4)
(b) Stack and subroutines (4)
(c) Address, data and control buses. (4)

(10 ME 13)

FOUR YEAR B.Tech. DEGREE EXAMINATION, NOVEMBER 2012

THIRD YEAR/FIRST SEMESTER

Branch - Mechanical Engineering

Paper — KINEMATICS OF MACHINERY

Time : 3 Hours

Max. Marks : 60

Answer ONE question choosing from each Unit.

UNIT - I

1. (a) Explain Whitworth Quick-return mechanism. (6)
- (b) How are Whitworth quick-return mechanism and crank and slotted-lever mechanism are different from each other? (6)

Or

2. A linkage has 14 links and the number of loops is 5. Calculate its
 - (a) Degrees of freedom
 - (b) Number of joints
 - (c) Maximum number of ternary links that can be had. Assume that all the pairs are turning pairs. (12)

UNIT - II

3. Using Freudenstein's equation derives for
 - (a) Displacement analysis
 - (b) Velocity analysis and
 - (c) Acceleration analysis for three point and five point positions. (12)

Or

4. A four - bar mechanism is required such that the input and output angles will be coordinates as below :

Input angle, $\theta_2 = 30^\circ \quad 50^\circ \quad 80^\circ$

Output angle, $\theta_4 = 0^\circ \quad 30^\circ \quad 60^\circ$

Synthesize the mechanism. (12)

[P.T.O]

UNIT - III

5. Explain four-bar slider crank position solution with a neat sketch. (12)

Or

6. In a simple steam engine, the lengths of the crank and the connecting rod are 100 mm and 400 mm respectively. The weight of the connecting rod is 50 kg and its centre of mass is 220 mm from the cross-head centre. The radius of gyration about the centre of mass is 120 mm. If the engine speed is 300 rpm, determine for the position when the crank has turned 45° from the inner - dead centre,
- (a) The velocity and acceleration of the centre of mass of the connecting rod.
 - (b) The angular velocity and acceleration of the rod.
 - (c) The kinetic energy of the rod. (12)

UNIT - IV

7. In a simple steam engine, the lengths of the crank and the connecting rod are 100 mm and 400 mm respectively. The weight of the connecting rod is 50 kg and its centre of mass is 220 mm from the cross-head centre. The radius of gyration about the centre of mass is 120 mm. If the engine speed is 300 rpm, determine for the position when the crank has turned 45° from the inner-dead centre,
- (a) The velocity and acceleration of the centre of mass of the connecting rod.
 - (b) The angular velocity and acceleration of the rod.
 - (c) The kinetic energy of the rod. (12)

Or

8. (a) Explain coriolis component of accelerations. (6)
(b) Explain velocity diagrams of various four bar mechanism. (6)

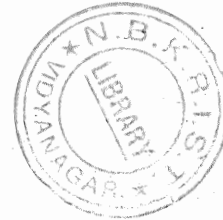

UNIT - V

9. (a) Derive the equation for minimum number of teeth. (6)
(b) What are the difference between cycloid teeth and involute teeth? (6)

Or

10. An epicyclic gear consists of a pinion, a wheel of 40 teeth and an annulus with 84 internal teeth concentric with the wheel. The pinion gears with the wheel and the annulus. The arm that carries the axis of the pinion rotates at 100 rpm. If the annulus is fixed, find the speed of the wheel; if wheel is fixed, find the speed for the annulus. (12)

(10 ME 13)

(10 CS 19)

FOUR YEAR B.Tech. DEGREE EXAMINATION, NOVEMBER 2012

THIRD YEAR/FIRST SEMESTER

Branch – CSE

Paper — DATABASE MANAGEMENT SYSTEMS

Time : 3 Hours

Max. Marks : 60

Answer ONE question from each Unit.

UNIT – I

1. (a) Explain the client-server architecture of the DBMS with a neat block diagram. (6)
- (b) Explain about Data Independence. (6)

Or

2. Explain about Entity-Relationship Model with an Example. (12)

UNIT – II

3. Explain the following with an example each : (12)
 - (a) Aggregate operations
 - (b) Integrity Constraints.

Or

4. Explain Tuple Relations Calculus and Domain Relational Calculus with Examples. (12)

UNIT – III

5. (a) What is Normalization? (3)
- (b) Consider a relation R with attributes ABCDE. Let the following FDs be given $A \rightarrow BC$, $BC \rightarrow E$ and $E \rightarrow DA$. Similarly, Let S be a relation with attributes ABCDE and the let the following FDs be given : $A \rightarrow BC$, $B \rightarrow E$ and $E \rightarrow DA$. You also do not know whether or which other join dependencies hold. (9)
 - (i) Is R in BCNF?
 - (ii) Is R in 4NF?

Or

6. (a) Explain multivalued dependencies with example. (6)
- (b) Explain 4th normal form. (6)

[P.T.O]

UNIT - IV

7. Explain about cost estimation in query optimization. (12)

Or

8. Explain ARIES recovery algorithm. (12)

UNIT - V

9. Explain about role based access control techniques. (12)

Or

10. Explain about encryption and public key infrastructures in purview of databases. (12)

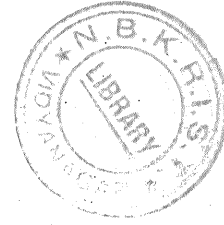

(10 CS 20)

B.Tech. DEGREE EXAMINATION, NOVEMBER 2012

THIRD YEAR/FIRST SEMESTER

Branch - CSE

Paper — DESIGN AND ANALYSIS OF ALGORITHMS

Time : 3 Hours

Max. Marks : 60

Answer ONE question from each unit.

UNIT - I

1. (a) Describe various asymptotic efficiency classes of an algorithms. (6)
- (b) Explain how to measure the time complexity of recursive algorithm with suitable example. (6)

Or

2. (a) Describe the characteristics of an algorithms. (4)
- (b) Write an algorithm to find maximum element of an array perform best, worst and average case complexities with appropriate order notation. (8)

UNIT - II

3. Write quick sort algorithm and apply it to sort the list E,X,A,M,P,L,E. (12)

Or

4. (a) State and explain convex hull problem. (4)
- (b) What is exhaustive search? Explain it with suitable example. (8)

UNIT - III

5. Define AVL tree Construct AVL tree for the following data items. How an AVL tree different from 2-3 tree 5, 6, 8, 3, 2, 4, 7. (12)

Or

6. What optimal binary search? How to construct optimal BST using dynamic programming? Explain with suitable example.

[P.T.O]

UNIT - IV

7. Apply Dijkstra algorithm to find shortest paths for the following problem (12)

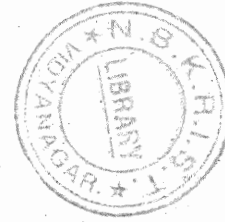
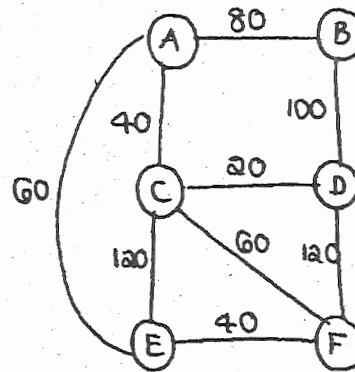

Or

8. (a) Explain the classes of P and NP (4)
(b) What is decision trees? Explain with suitable example. (8)

UNIT - V

9. (a) Discuss about architecture constraints in parallel algorithm. (4)
(b) Describe the performance measures of parallel algorithms. (8)

Or

10. (a) Explain how sorting performed on meshes. (4)
(b) Write short notes on PRAM. (8)

(10 CS 02)

B.Tech. DEGREE EXAMINATION, NOVEMBER 2012
THIRD YEAR/FIRST SEMESTER
Branch - Computer Science and Engineering
Paper — ADVANCED COMPUTING TECHNOLOGIES

Time : 3 Hours

Max. Marks : 60

Answer ONE question from each Unit.

UNIT - I

1. (a) How many ways are possible in Java to create multiple threaded programs? Discuss the differences between them.
- (b) Discuss about Byte code interpretation in Java Technology.

Or

2. (a) Write a detailed note on Dynamic Reflexive classes.
- (b) Explain about Java I/O Streaming.

UNIT - II

3. (a) What are some advantages and disadvantages of Java Sockets?
- (b) What is the difference between message producer and message consumer?

Or

4. (a) How to transport your own custom objects? Discuss.
- (b) What is the role of JMS in enterprise solution development? Explain.

UNIT - III

5. (a) What are the different conditions that has to be kept in mind when using serialization concept?
- (b) Define the purpose of Externalizable Interface.

Or

6. (a) What are the different types of classes that are used in RMI? Discuss.
- (b) Explain semaphore and monitors in Java threading.

[P.T.O.]

UNIT - IV

7. Write a Java program to read the data from and write data to servlet using data input/output streams.

Or

8. What is the JDBC? Explain two-tier JDBC model and three-tier JDBC model.

UNIT - V

9. (a) What makes J2EE suitable for distributed multitiered applications? Explain.
(b) What is deployment descriptor? Explain.

Or

10. (a) Describe the components of J2EE application.
(b) What is the difference between Container-Managed Persistent (CMP) bean and Bean-Managed Persistent (BMP)? Explain.



(10 CS 42)

B.Tech. DEGREE EXAMINATION, NOVEMBER 2012

FIRST SEMESTER

Branch - CSE

Paper — THEORY OF COMPUTATION

Time : 3 Hours

Max. Marks : 60

Answer ONE question from each Unit.

UNIT - I

- (a) Design DFA which accepts set of all strings which are divisible by 5 over the binary alphable.
(b) Convert the following NFA with ϵ -transition into NFA without ϵ -transition.

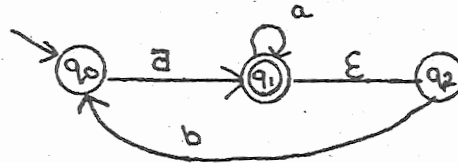

Or

- (a) Differentiate moore and mealay machines.
(b) Construct minimization of DFA for the following.

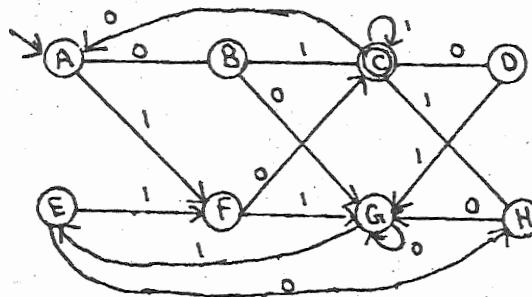

UNIT - II

- Give the regular expression for the following language over the alphabet $\{0, 1\}$.
 - Set of all binary strings whose 3rd symbol from the left end is 1.
 - All the strings containing not more than three 0's.
 - All the strings in which atmost two zero's.
 - All the strings has odd length.

Or

[P.T.O]

4. (a) Let R be a RE then there exists an NFA with ϵ -moves that accepts L(R).
 (b) Find Regular expression that represents the following diagram.



UNIT - III



5. (a) Construct CNF for the following CFG.
 $E \rightarrow E + T/T$
 $T \rightarrow T * F/F$
 $F \rightarrow (E)/a$
 (b) Check the following grammar is ambiguous or not $S \rightarrow SaSaS/b$.

Or

6. (a) Design PDA for the language $L = \{a^n b^m a^n / m, n \geq 1\}$
 (b) Explain deterministic PDA and non-deterministic PDA.

UNIT - IV

7. (a) Prove that language $L = \{ww/w \in (0 + 1)^*\}$ is not CFL.
 (b) Prove that CFL are not closed under intersection.

Or

8. Design turing machine for the language $L = \{w \subset w^R / w \in \{a, b\}^*\}$.

UNIT - V

9. (a) State and prove RICE theorem.
 (b) Define recursive and recursively enumerable languages and specify the relationship between them.

Or

10. (a) State and explain post correspondence problem
 (b) Write the CSG for the following CSL $L = \{a^n b^n c^n / n \geq 1\}$.

(10 CS 34)

B.Tech. DEGREE EXAMINATION, NOVEMBER 2012

THIRD YEAR/FIRST SEMESTER

Branch CSE

Paper — OPERATING SYSTEMS

Time : 3 Hours

Max. Marks : 60

Answer ONE question from each Unit.

UNIT - I

1. (a) Explain DMA with neat diagram.
- (b) Describe services of operating systems.

Or

2. (a) Discuss various categories of system calls.
- (b) What are the important features of embedded and timesharing systems.

UNIT - II

3. Explain about single threaded and multi- threaded process models with suitable diagrams

Or

4. State dining philosopher's problem and show how to allocate the several resources among several processes in a deadlock and starvation free manner

UNIT - III

5. Consider the following page reference string 7, 0, 1, 2, 0, 3, 0, 4, 2, 3, 0, 3, 2, 1, 2, 0, 1, 7, 0.
1. Calculate the page fault rate for the following algorithms

- (a) FIFO replacement
- (b) Optimal replacement.

Or

6. (a) What is thrashing? When does it occur? Explain.
- (b) Describe the structure of page table.

UNIT - IV

7. (a) Discuss about N - step- SCAN policy for disk scheduling.
- (b) Discuss the objectives for file management systems.

Or

8. (a) Discuss the resource allocation graph algorithm for deadlock detection
- (b) Explain about RAID levels.

[P.T.O.]

UNIT - V

9. (a) Explain the various password selection strategies.
(b) Discuss about UNIX password scheme.

Or

10. (a) Write a brief note on intrusion detection
(b) Write about Access control list of Windows 2000.
-

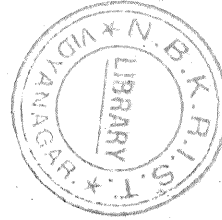

(10 CS 16)

B.Tech. DEGREE EXAMINATION, NOVEMBER 2012

FIRST SEMESTER

Branch — CSE

Paper — DATA COMMUNICATION

Time : 3 Hours

Max. Marks : 60

Answer FIVE questions, choosing ONE question from each Unit.

All questions carry equal marks.

UNIT - I

1. What are the responsibilities of Data link layer and Network layer?

Or

2. Explain the protocol architecture of TCP/IP.

UNIT - II

3. (a) Define Data transmission.

- (b) Write difference between Analog and digital Transmission and how can you convert Analog data into digital form.

Or

4. Write short notes on :

(a) Optical fiber

(b) Twisted pair

UNIT - III

5. Write short notes on :

(a) Line-of-site Transmission

(b) Multipath

Or

6. For the following Bit sequence 10110 draw scheme for unipolar, NRZ-I, NRZ-L, RZ, DME.

[P.T.O]

UNIT - IV

7. Explain Error correction with an example.

Or

8. Explain the following for noisy channel :

- (a) Stop-and-wait ARQ
- (b) Go-Back-N ARQ
- (c) Selective Repeat ARQ.



UNIT - V

9. Explain XDSL briefly.

Or

10. Explain frequency hopping spread spectrum.

(10 EI 03)

B.Tech. DEGREE EXAMINATION, NOVEMBER 2012

THIRD YEAR/ FIRST SEMESTER

Branch -EICE

Paper - ELECTRICAL MEASUREMENTS AND INSTRUMENTS

Time : 3 Hours

Max. Marks : 60

Answer any ONE question from each Unit.

UNIT - I

1. (a) Give the construction and principle operation of PMMC instrument. (6)
- (b) What is the Torque equation of PMMC instrument? Write its advantages and Disadvantages. (6)

Or

2. (a) Explain the construction and working principle of Repulsion type moving Iron Instruments. (6)
- (b) Write about Rectifier type voltmeter. (6)

UNIT - II

3. (a) Give the construction and working of Electrodynamic meter type wattmeter. (6)
- (b) List various errors in electro dynamometer type wattmeter and how they are compensated. (6)

Or

4. (a) Explain the operation of Induction type of energy meter with the help of neat diagram. (6)
- (b) Write about Calibration of energy meters. (6)

UNIT - III

5. (a) Explain the working potential Transformer (P.T). (6)
- (b) Draw the phassor diagram of current Transformer. (6)

Or

6. (a) What are the different types of potentiometer and also write about advantages of those. (6)
- (b) Compare D.C. and A.C. potentiometers. (6)

[P.T.O]

UNIT - IV

7. (a) Explain Kelvin Double Bridge Method for measurement of Resistance. (6)
- (b) The diagram shows a wheatstone Bridge with values of the bridge elements as show. Find out unknown Resistance. (6)

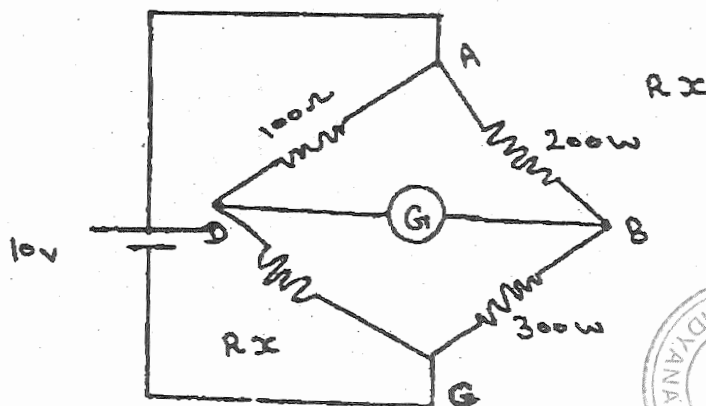

Or

8. (a) List out different methods used for Measurement of high resistance and also explain any one method in detail. (6)
- (b) Write about earth resistance measurement. (6)

UNIT - V

9. (a) Derive the equation of balance for an Anderson's Bridge. Discuss the Advantages and Disadvantages of the Bridge. (6)
- (b) Write about sources and detectors used for A.C. Bridges. (6)

Or

10. (a) Explain how Hay's bridge is used for measurement of unknown inductance at balance condition. (6)
- (b) Write about error in A.C. Bridge methods and their compensation. (6)

(10 EC 16)

B.Tech. DEGREE EXAMINATION, NOVEMBER 2012

THIRD YEAR/FIRST SEMESTER

Branch - EICE

Paper — COMMUNICATION ENGINEERING

Time : 3 Hours

Max. Marks : 60

Answer any ONE question from each Unit.

UNIT - I

1. (a) Define modulation. Explain and compare different types of amplitude modulation and compare them. (6)
- (b) A signal $\left\{ x(t) = \cos 2\pi 40 t + \frac{1}{2} \cos 2\pi 90 t \right\}$ and carrier at 10 kHz given as input to a square law AM modulator with i/o relation given by $Y(t) = a_1 x(t) + a_2 x^2(t)$ to produce standard AM signal. Find the value of 'a₁' and 'a₂' f.t $A_c = 10$ and $m_q = 0.5$. Refer to figure shown. (6)

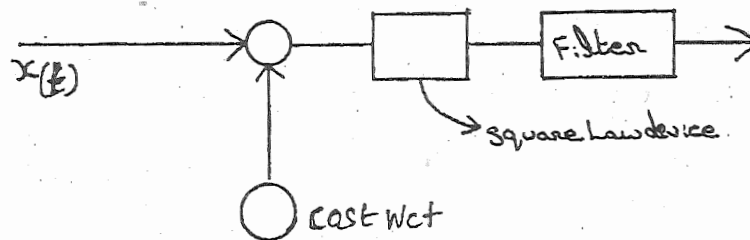

Or

2. (a) Explain the advantages and disadvantages of SSB, and hence discuss how VSB generation over comes the disadvantages of SSB. Explain the generation of VSB using block schematic. (8)
- (b) Compare spectra of normal AM, SSB and VSB and give your comments. (4)

UNIT - II

3. (a) Define NB and WB frequency modulation and give the principle of generation of NBFM. (4)
- (b) Discuss clearly the Carson's rule in wide band FB and hence derive the Bandwidth of WBFM from principle. (8)

Or

[P.T.O]

4. (a) Differentiate between NBFM, WBFM and PM and clearly bring out the salient features of each. (6)
- (b) What is frequency deviation? Derive expression for frequency deviation of FM and hence define Carson's rule. (6)

UNIT - III

5. (a) Define sampling theorem and discuss its application for low pass and band pass signals. (6)
- (b) Define and distinguish between types of pulse modulations. (6)

Or

6. (a) Explain clearly TDM and FDM systems and give the merits and demerits of each. (6)
- (b) Explain clearly the generation and detection of pulse position modulated signal. (6)

UNIT - IV

7. (a) Explain clearly about the generation of pulse code modulation and bring out the advantages of DPCM over PCM. (6)
- (b) Explain the role of digital modulations and hence describe the generation and detection of BPSK. (6)

Or

8. (a) Compare PCM, DCPM, DM and ADM w.r.t bit rate, signal variation and hence define over slope error and granular noise. (8)
- (b) What is companding? Explain clearly the principle and need for companding. (4)

UNIT - V

9. (a) Explain the working of superheterodyne receiver in detail with the help of its block diagram. (6)
- (b) Define telemetry and discuss about land line telemetry and RF telemetry. (6)

Or

10. (a) Discuss clearly about the working of TRF receiver and explain in detail how the disadvantages at it are overcome in superheterodyne receiver. (8)
- (b) Explain and compare voltage telemetry and current telemetry. (4)



(10 EC 16)

(10 EC 18)

B.Tech. DEGREE EXAMINATION, NOVEMBER 2012

THIRD YEAR/FIRST SEMESTER

Branch - EICE

Paper — MICROPROCESSOR AND MICROCONTROLLERS

Time : 3 Hours

Max. Marks : 60

Answer any ONE question from each Unit.

UNIT - I

1. (a) Explain clearly the architecture of 8086 microprocessor (MP). (8)
- (b) Discuss conditional and control flags of 8086 mp. (4)

Or

2. (a) Differentiate between effective address and physical address in 8086 mp. (4)
- (b) State the advantages of relative addressing mode, compared to direct addressing mode. (4)
- (c) Explain how is pipelining used in the internal architecture of 8086 mp. (4)

UNIT - II

3. (a) What is the purpose of assembler directives? Explain all assembly directives of 8086 mp. (6)
- (b) Write an ALP of 8086 to arrange the given array of data bytes in ascending order using bubble sort algorithm. (6)

Or

4. (a) Describe different tools used in Assembly language programming. (6)
- (b) Write a program to convert Hexadecimal number (00 to 0F) into decimal numbers using look up table. (6)

[P.T.O]

UNIT - III

5. (a) Explain the importance of 8259 interrupt controller and explain how does it handle the interrupt. (6)
- (b) What is DMA? Explain DMA data transfer method in detail. (6)

Or

6. (a) Explain different methods of a data transfer schemes. (6)
- (b) Draw the internal block diagram of 8251 and explain each block. (6)

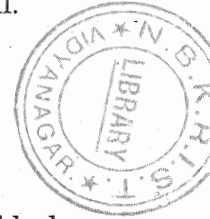

UNIT - IV

7. Draw the interfacing diagram for 8086 based system (minimum mode) with the following specifications :
- (a) 16 KB RAM
- (b) 8 KB EPROM.

Also show the required latches, buffers and decoders. Draw the memory map for the above interface. (12)

Or

8. Interface an 8-bit DAC with 8086 through 8255. Write an ALP of 8086 MP to produce the following periodic wave form. (12)

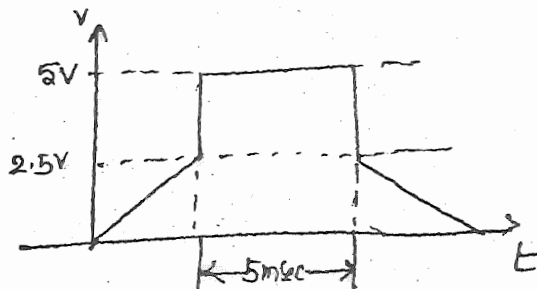

UNIT - V

9. (a) Explain the architecture of 8051 micro-controller with a neat diagram. (6)
- (b) Explain different modes of operation of serial communication. (6)

Or

(10 EC 18)